

Rheonics SRV Inline Viscometer	
Material	316L
Process Connection	Varinline N Machined
Order Code	SRV-X4-VNM

Varinline N Flange/Plug is machined with a cut to maintain minimum area around the sensing element

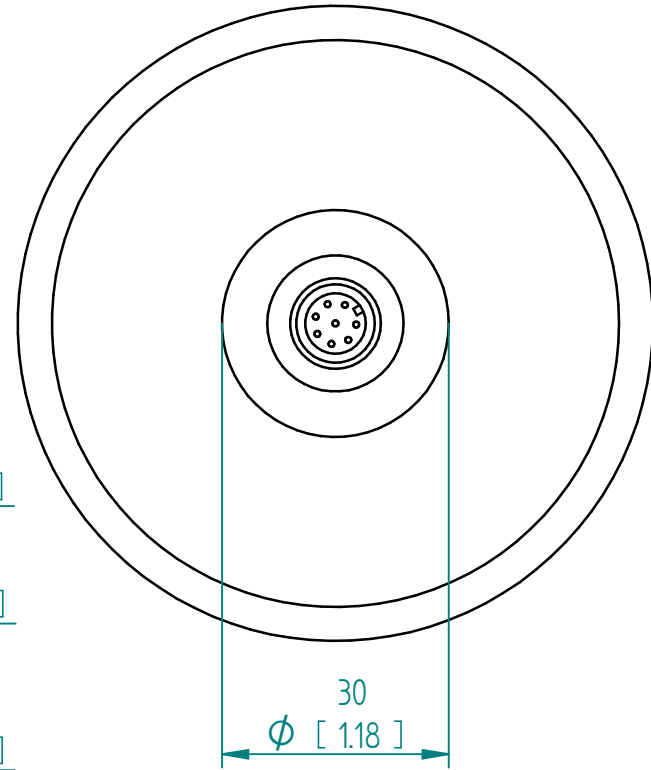
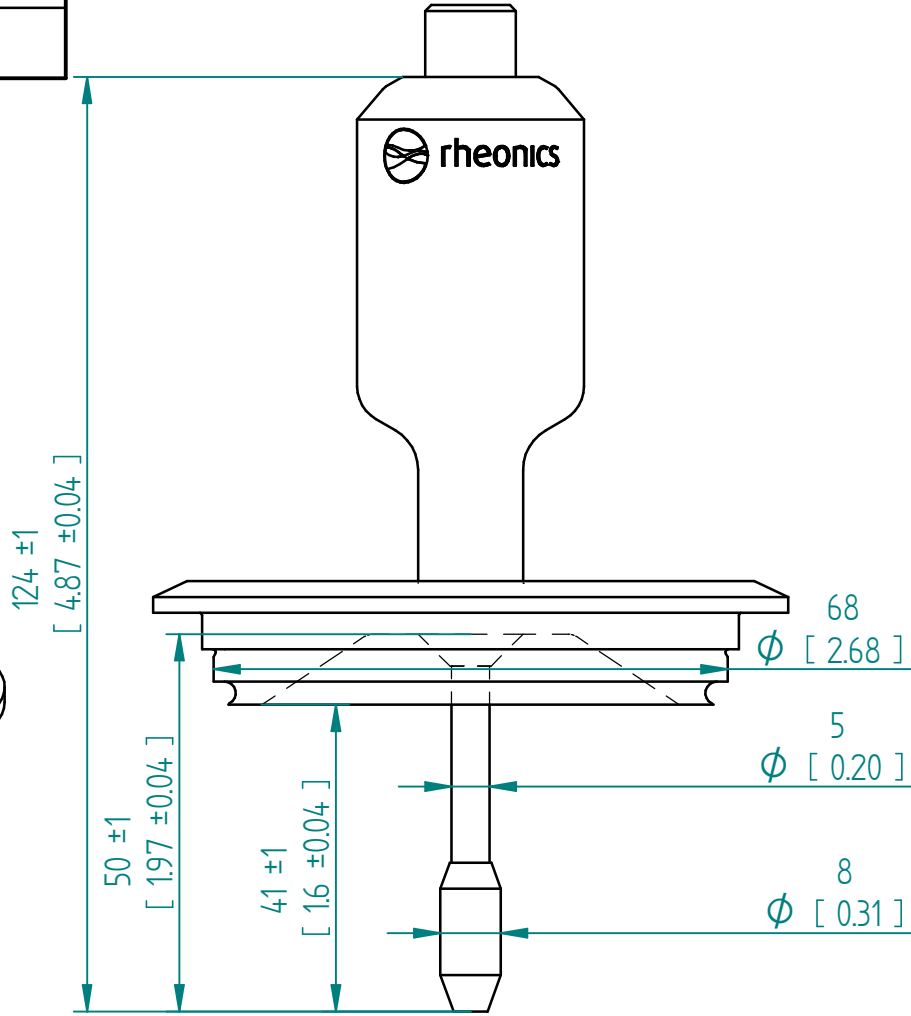
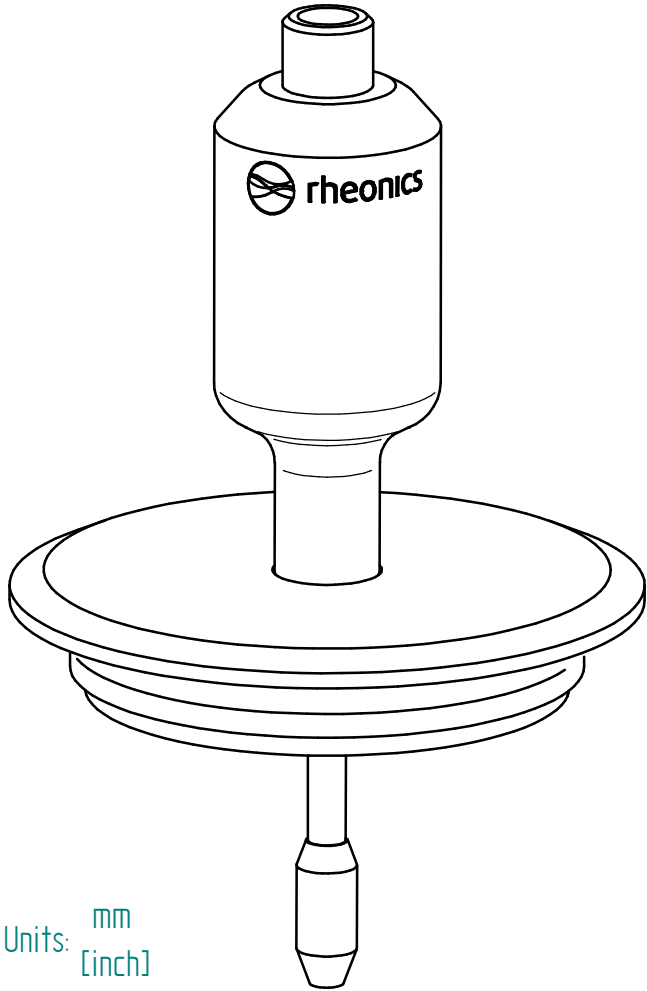

Units: mm
[inch]

SRV-X4-VNM Varinline N Machined

This drawing remains property of rheonics. It may be neither copied nor informed to third persons or competitors without our approval. (2 paragraph 1 fig.7 copyright act of 9th Sept. 1965)



Protected by US and International patents granted and pending

Rheonics SRV Inline Viscometer

Material	316L
Process Connection	Varinline N Machined
Order Code	SRV-X4-VNM

1	Name	Varinline Housing DN50
	GEA Code	Varinline TDN50
	Rheonics Code	IFC-V50
	Inlet/Outlet	Welding Ports
2	Name	Varinline N Blind Plug
	GEA code	Varinline N Plug
	Rheonics Code	PLG-VN

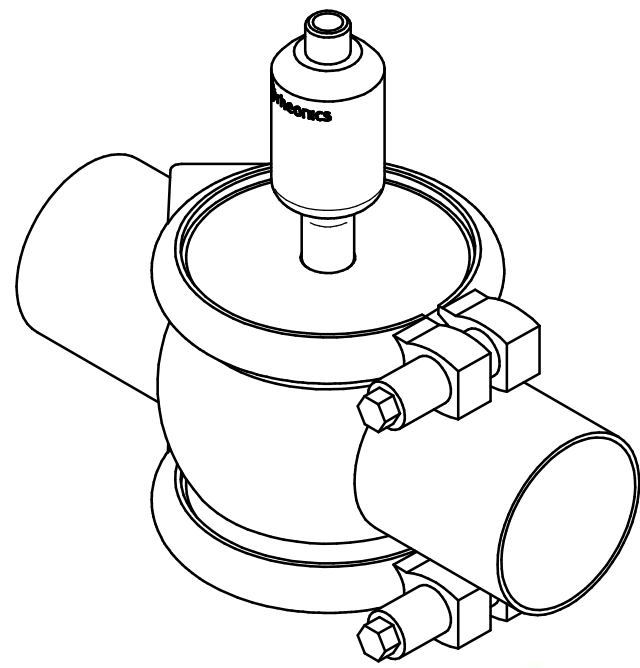
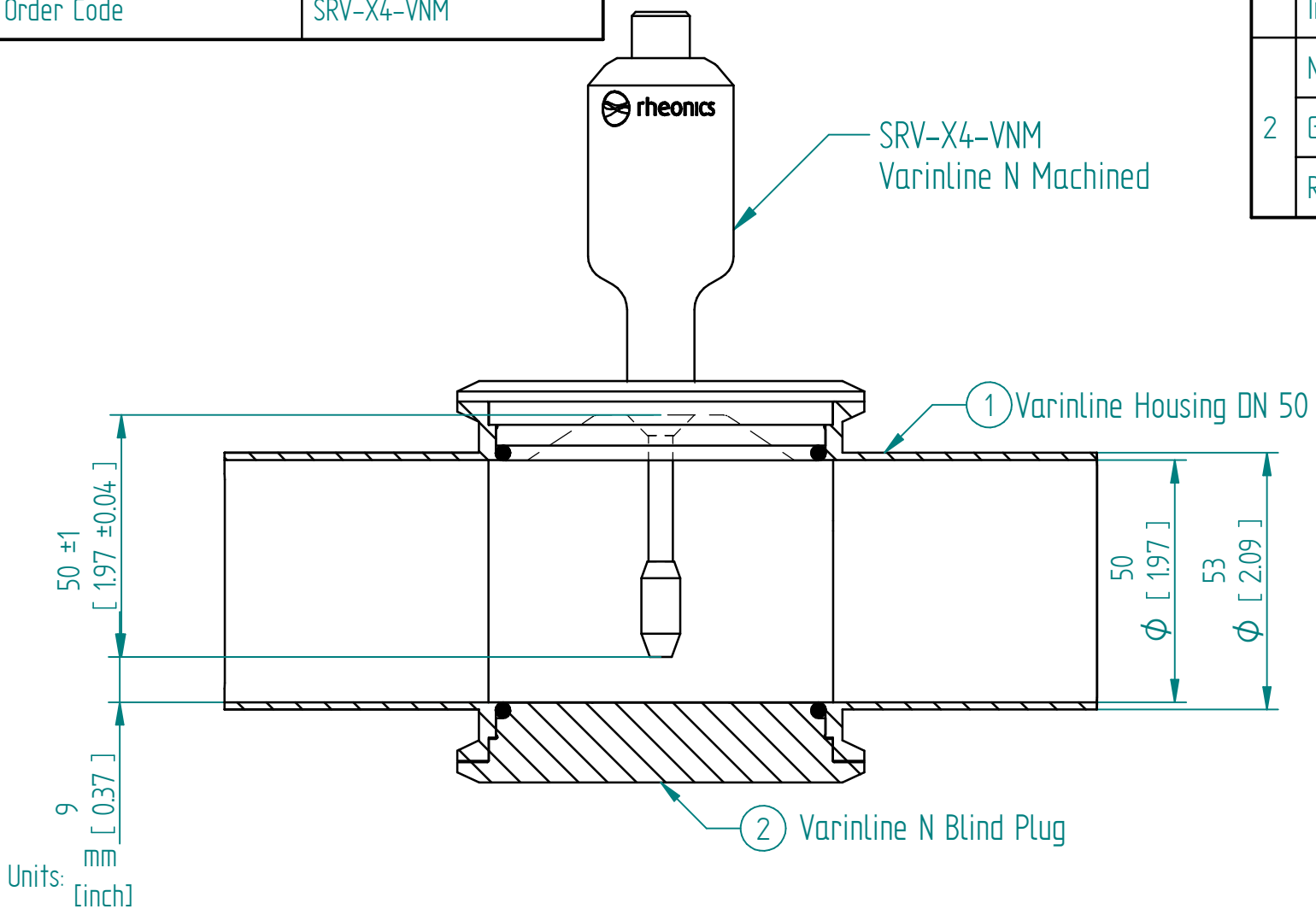

rheonics

inline process
density and viscosity
monitoring

SRV-X4-VNM Varinline Housing DN50

No warranty is made for the correctness of the third party drawings. Dimensions are adapted from publically available drawings. Customer should check and confirm that the retrofit sensor has the dimensions and flange specifications for a correct installation in their existing location.
This drawing remains property of rheonics. It may be neither copied nor informed to third persons or competitors without our approval. (2 paragraph 1 fig.7 copyright act of 9th Sept. 1965)

Protected by US and International patents granted and pending