

# Rheonics SRV Inline Viscometer

Material	316L
Process Connection	Varinline N Machined
Order Code	SRV-X4-VNM

Varinline N Flange/Plug is machined with a cut to maintain minimum area around the sensing element

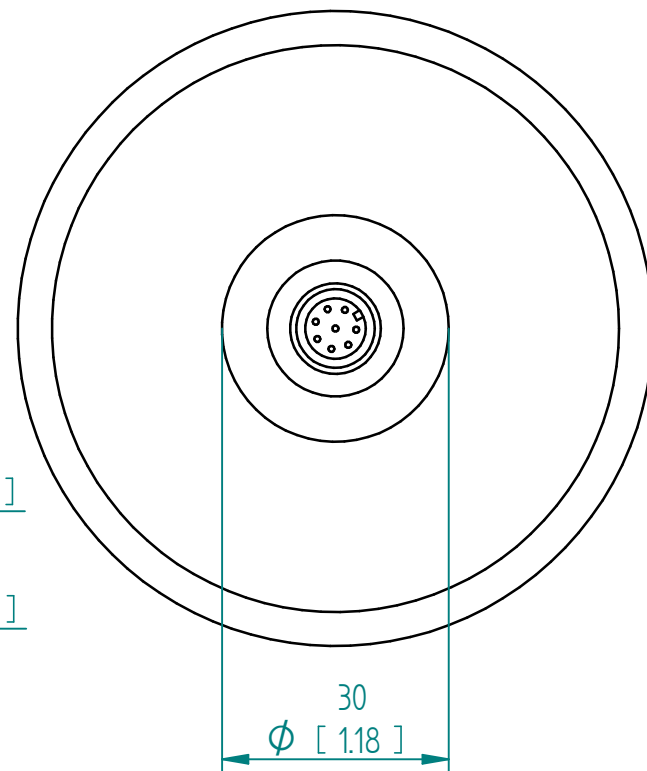
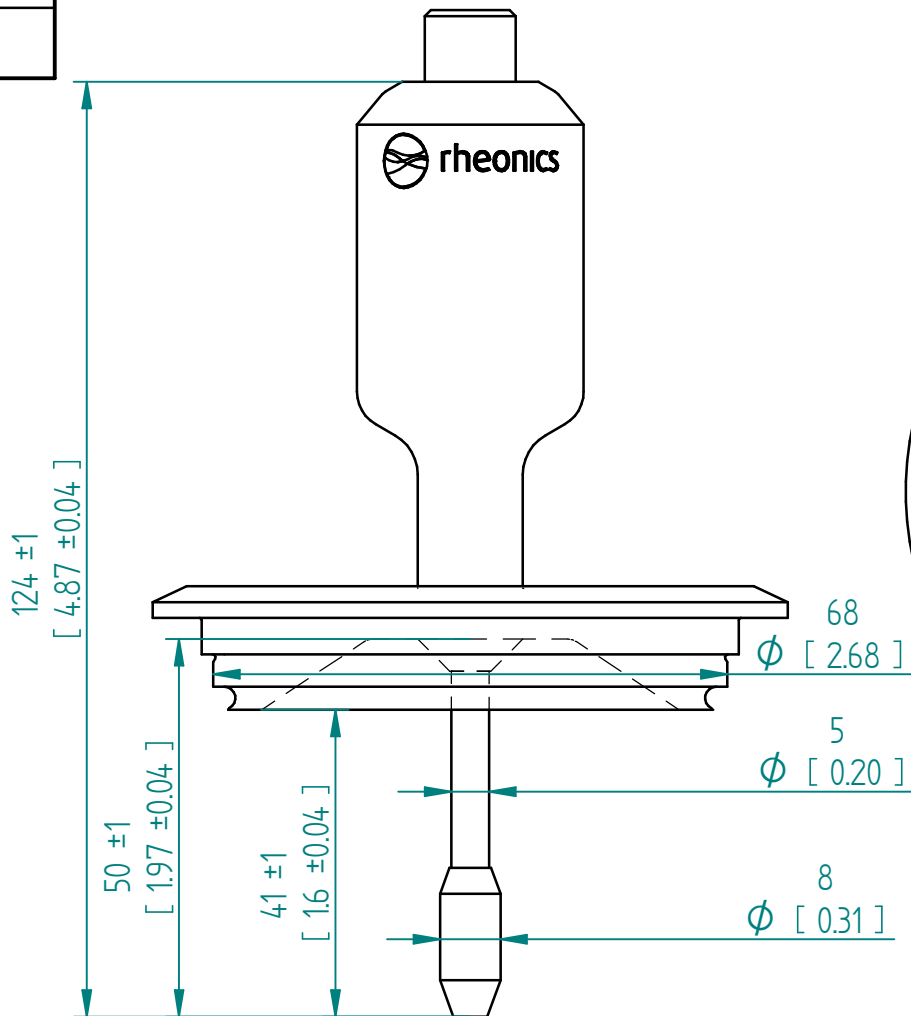
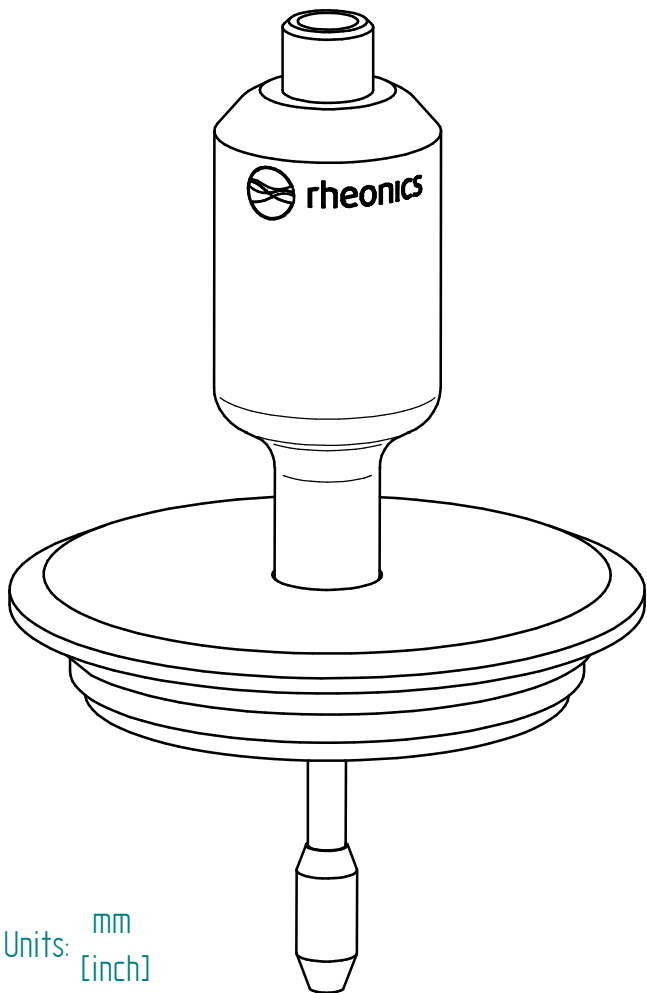

Units: mm [inch]

## SRV-X4-VNM Varinline N Machined

This drawing remains property of rheonics. It may be neither copied nor informed to third persons or competitors without our approval. ( 2 paragraph 1 fig.7 copyright act of 9th Sept. 1965)



Protected by US and International patents granted and pending