

SRV-HD-X5-Axxx-B1N25 (P)		
X5	Installation	
A	Insertion Depth	Custom
B	Connection	Thread
	Type	NPT 1.25"-11.5

Custom Flange (F)	
Connection	Flange
Norm	
Size	
Pressure Rating	
Threaded hole	1.25" NPT
Who provides	<input type="checkbox"/> Rheonics <input type="checkbox"/> Customer

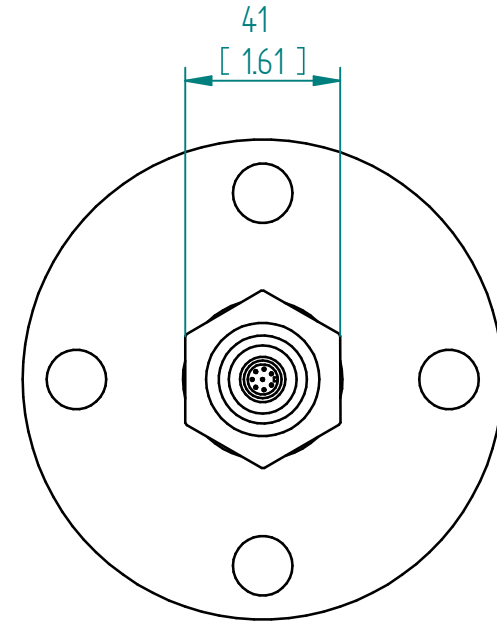
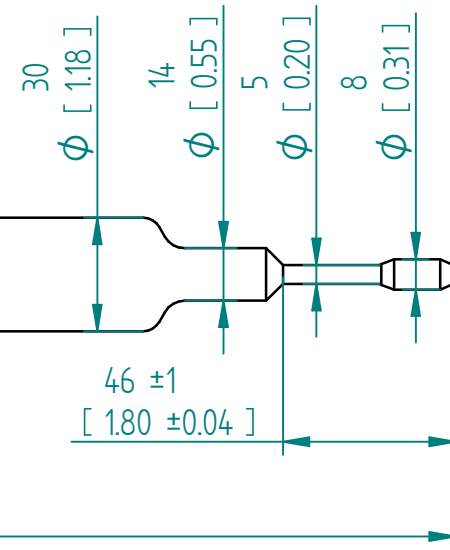
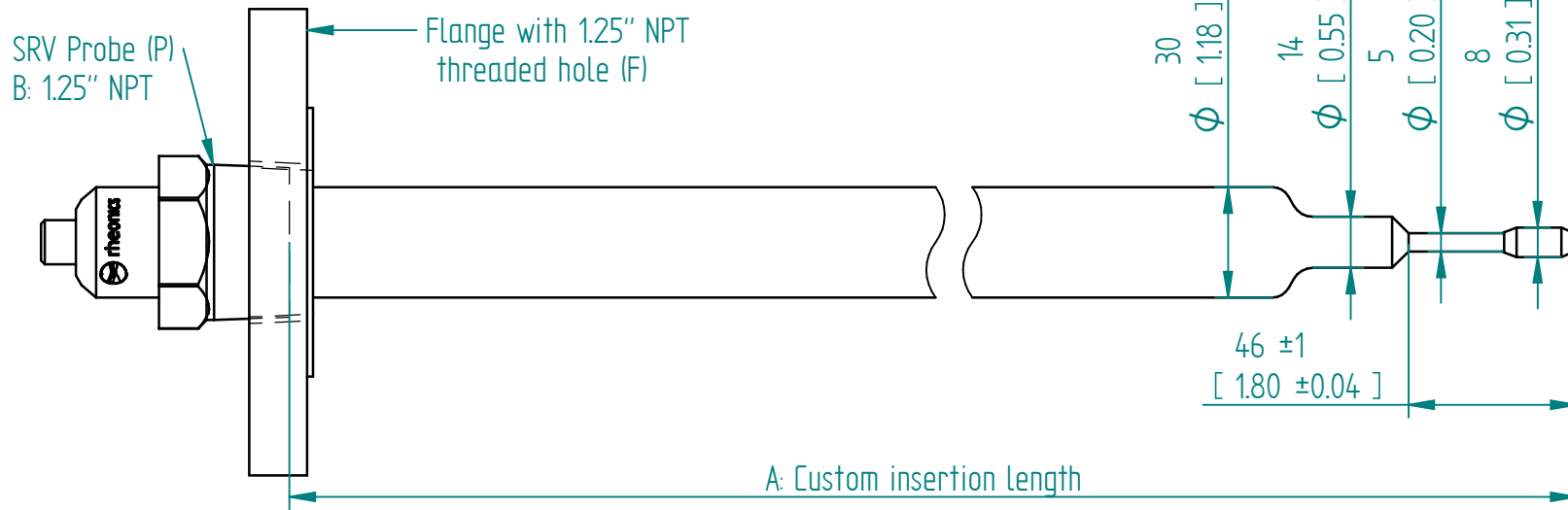
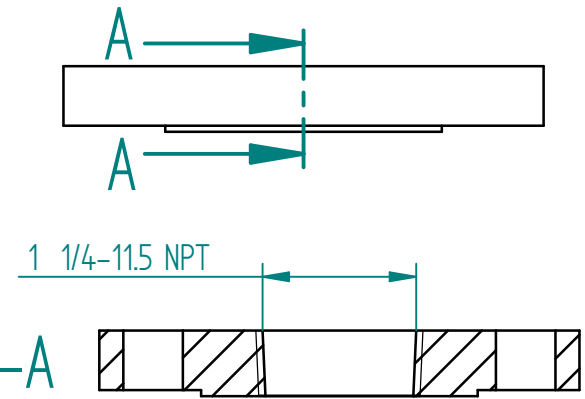

Units: mm
[inch]

SRV-HD-X5-Axxx-B1N25 Threaded Flange

This drawing remains property of rheonics. It may be neither copied nor informed to third persons or competitors without our approval. (2 paragraph 1 fig.7 copyright act of 9th Sept. 1965)



Protected by US and International patents granted and pending

Flange can be 1.5" or bigger.
 Care should be taken during assembly to not hit the sensing element.

SRV-HD-X5-Axxx-B1N25 (P)		
X5	Installation	
A	Insertion Depth	Custom
B	Connection	Thread
	Type	NPT 1.25"-11.5

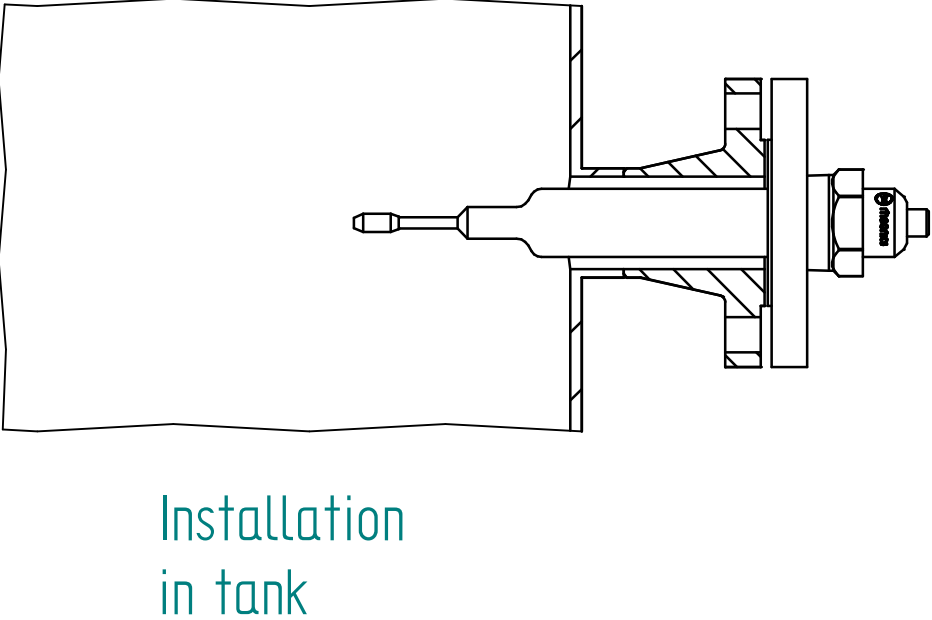
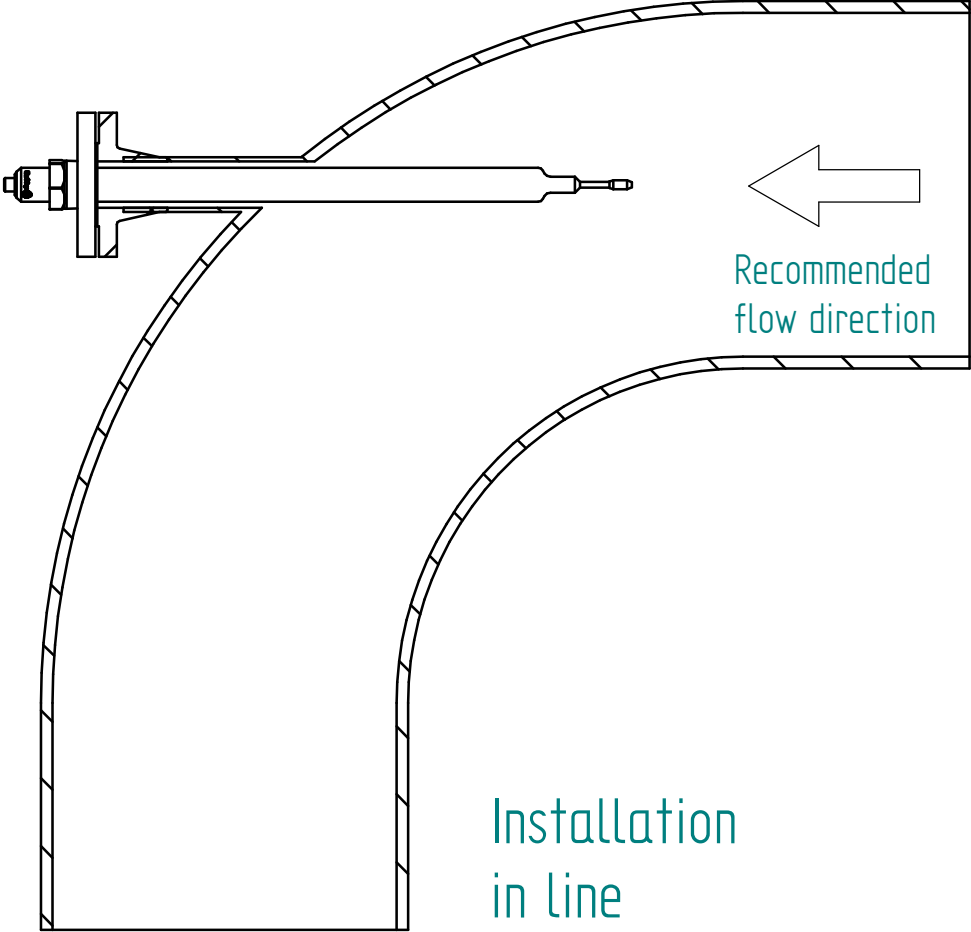

Units: mm
 [inch]

**SRV-HD-X5-Axxx-B1N25
 Threaded Flange**

This drawing remains property of rheonics. It may be neither copied nor informed to third persons or competitors without our approval. (2 paragraph 1 fig.7 copyright act of 9th Sept. 1965)



Protected by US and International patents granted and pending