

Material	PTFE
Max. Volume	21 ml
Description	Calibration cylinder for SRV probe

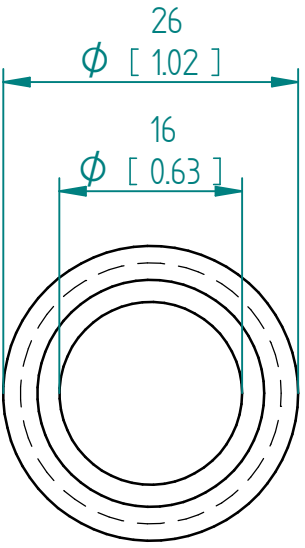
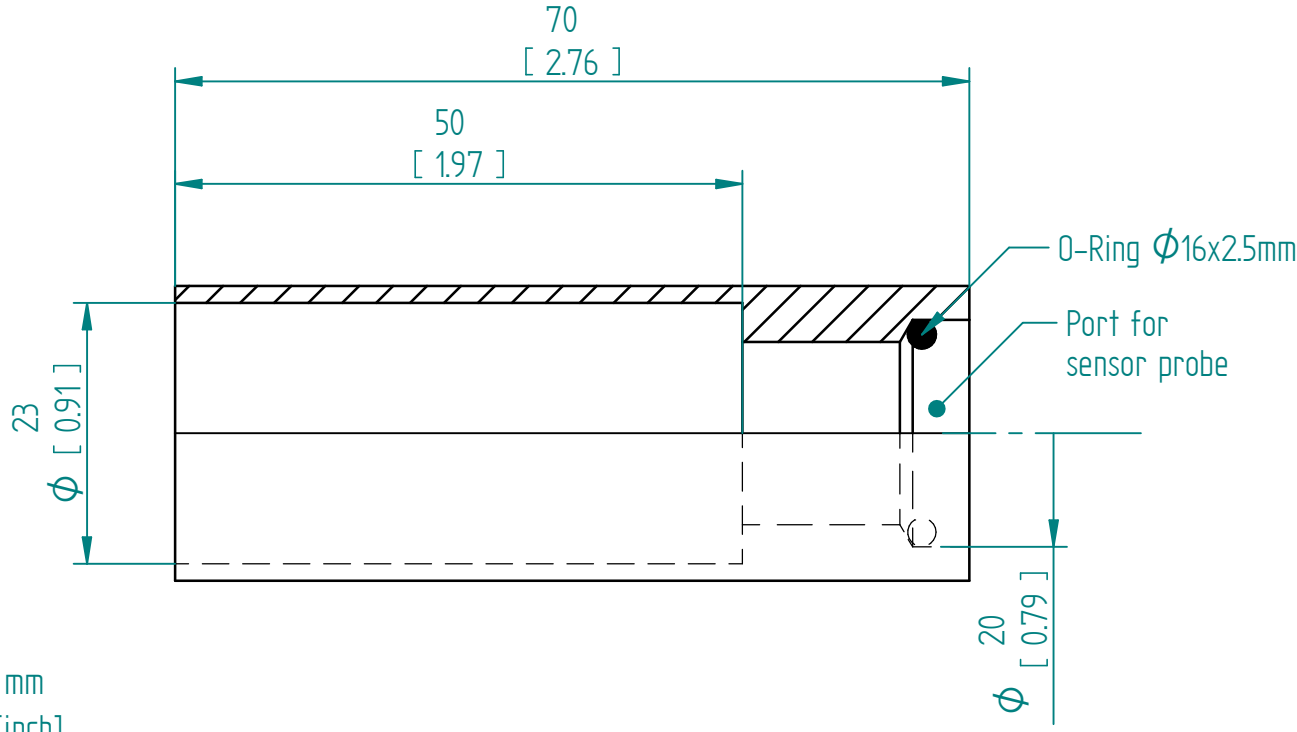
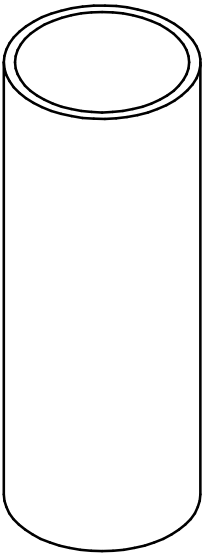

Units: mm [inch]

SCC-SRV
Calibration cylinder for SRV

This drawing remains property of rheonics. It may be neither copied nor informed to third persons or competitors without our approval. (2 paragraph 1 fig.7 copyright act of 9th Sept. 1965)

Protected by US and International patents granted and pending



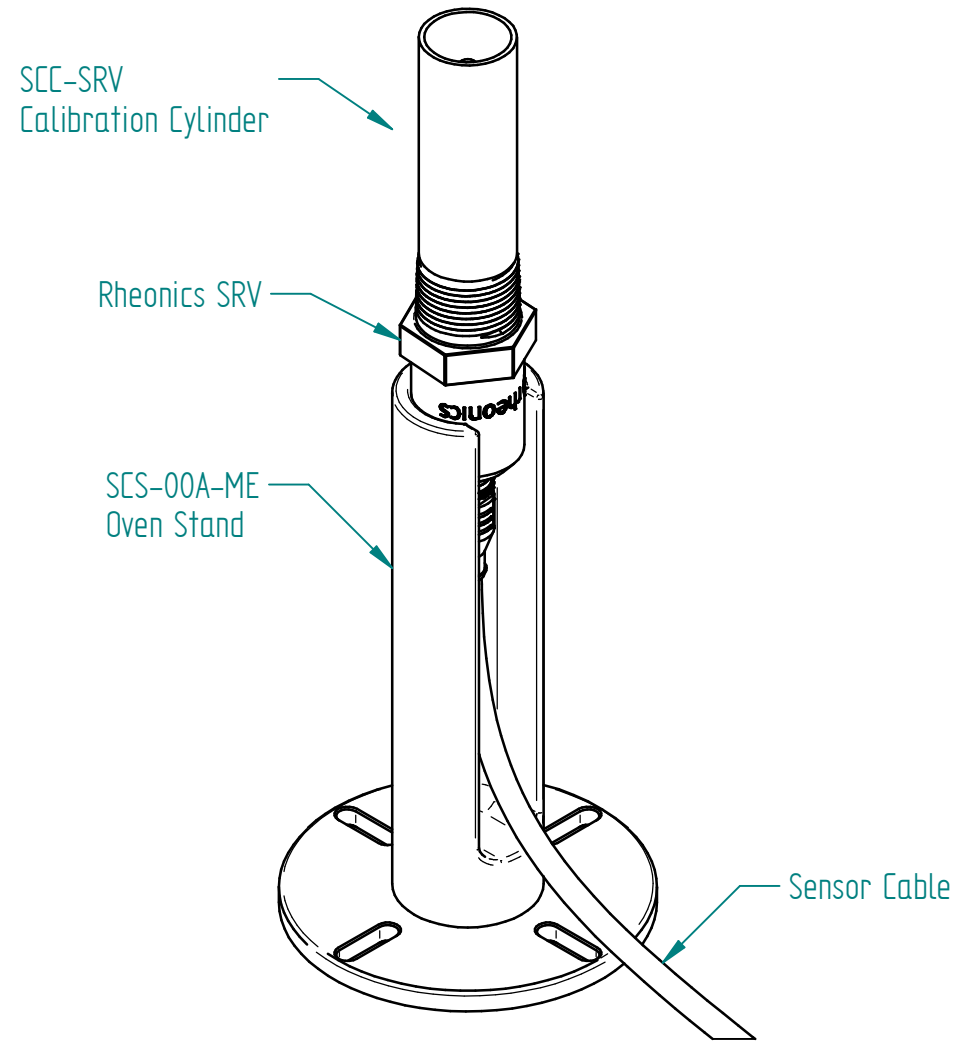
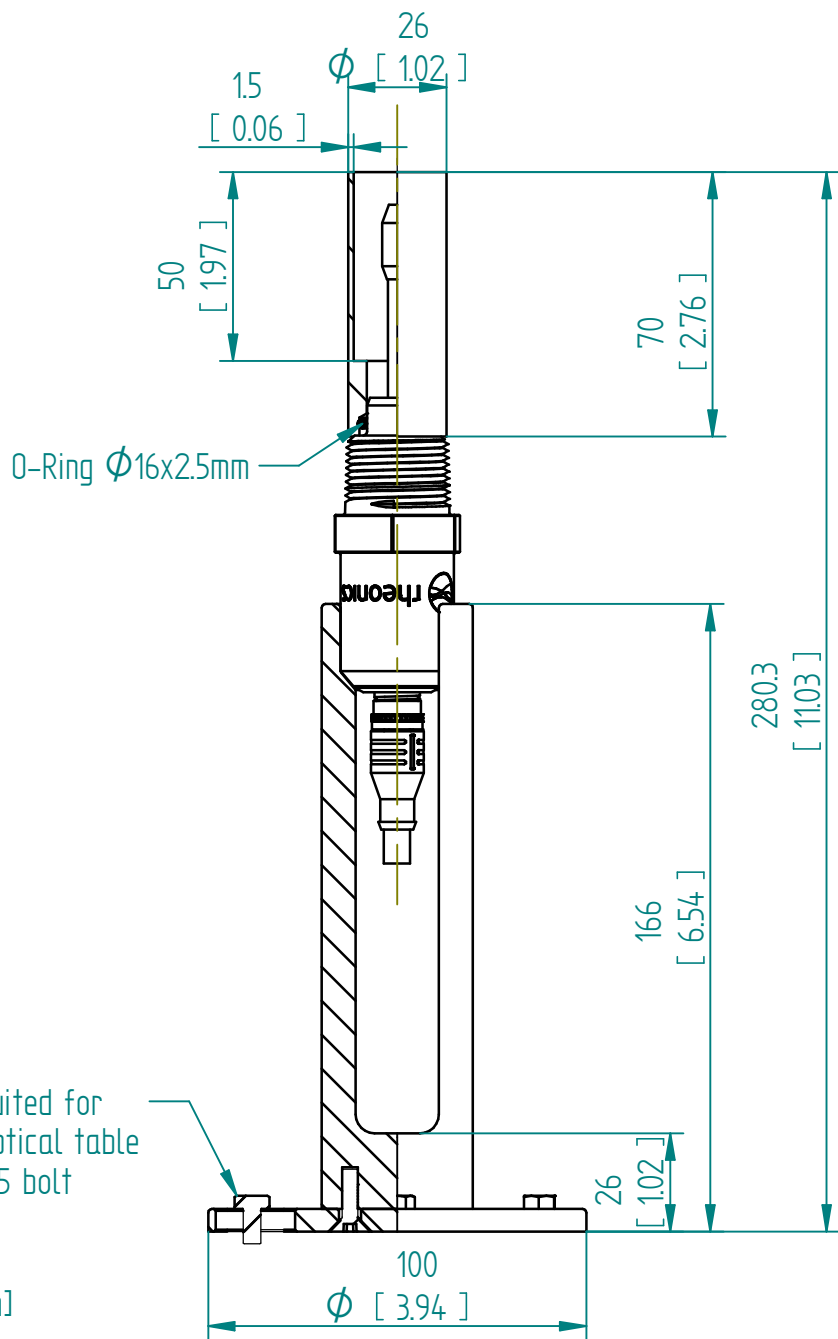

Units: mm
[inch]



inline process
density and viscosity
monitoring

Sensor Probe Laboratory Setup

This drawing remains property of rheonics. It may be neither copied nor informed to third persons or competitors without our approval. (2 paragraph 1 fig.7 copyright act of 9th Sept. 1965)

Protected by US and International patents granted and pending