

Material	PTFE
Max. Volume	66 ml
Description	Calibration cylinder for SRD probe

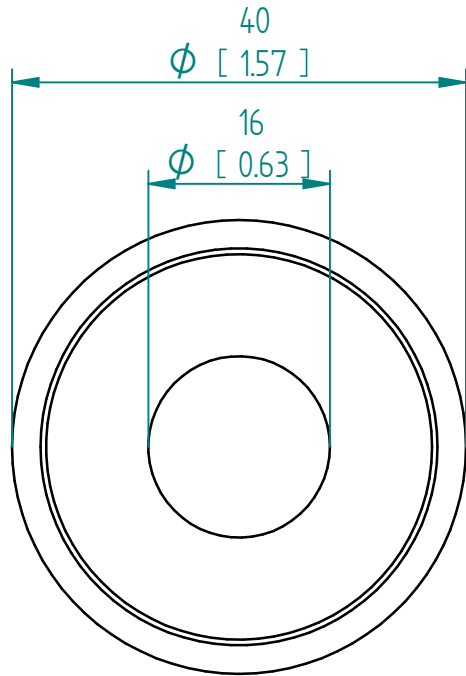
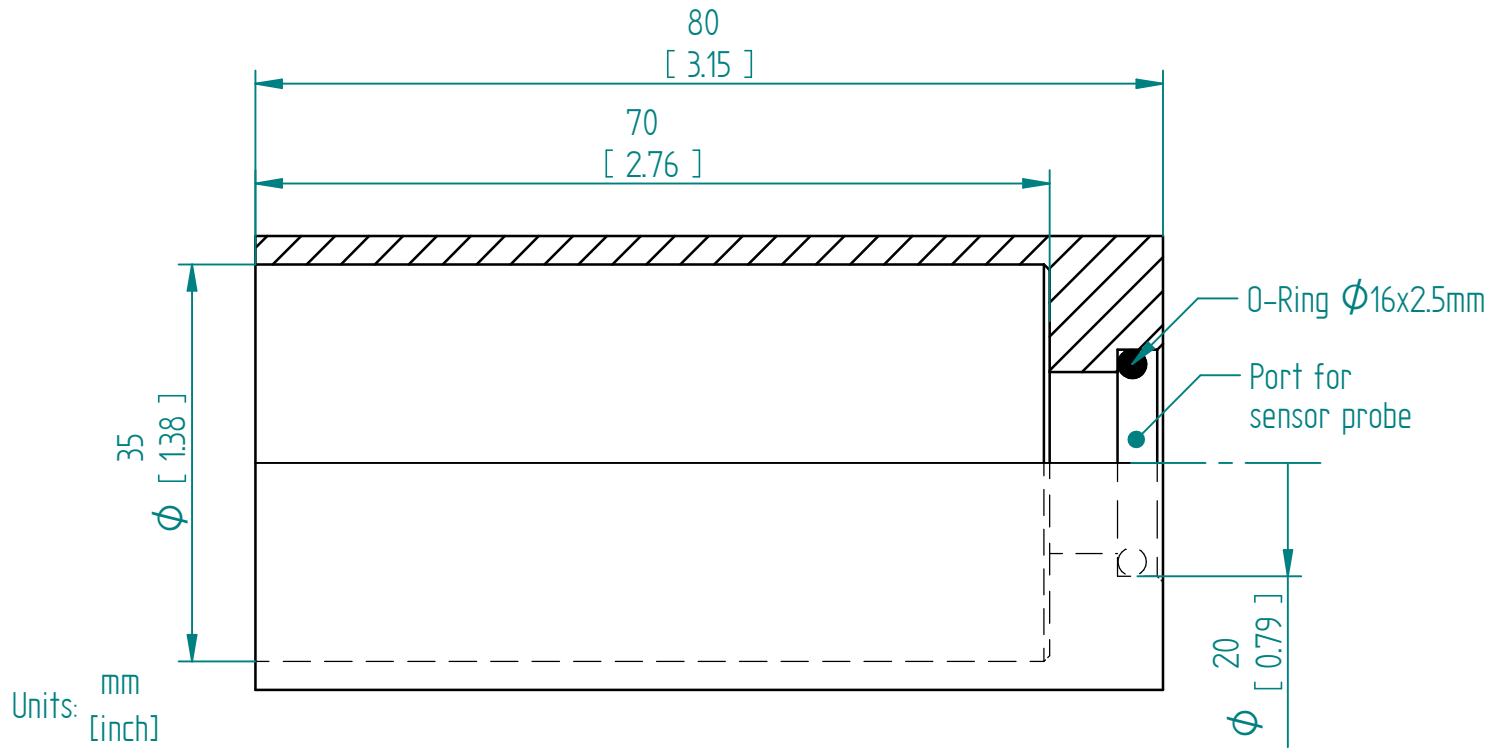
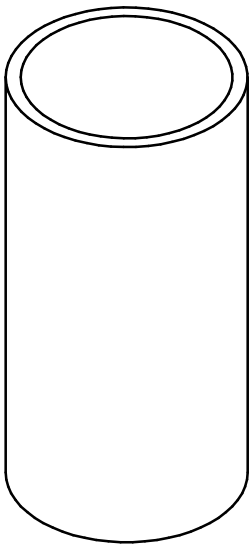

SCC-SRD
Calibration Cylinder for SRD

This drawing remains property of rheonics. It may be neither copied nor informed to third persons or competitors without our approval. (2 paragraph 1 fig.7 copyright act of 9th Sept. 1965)

Protected by US and International patents granted and pending



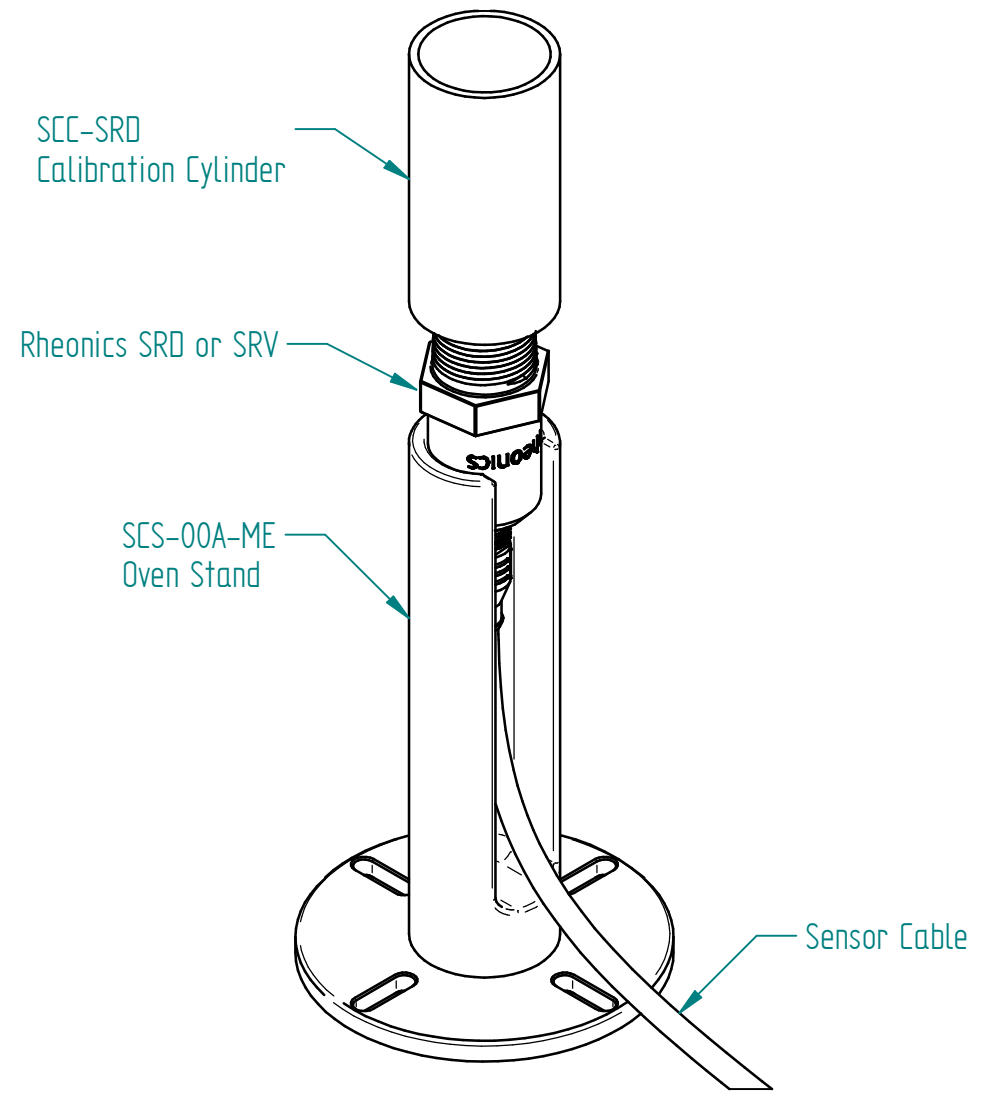
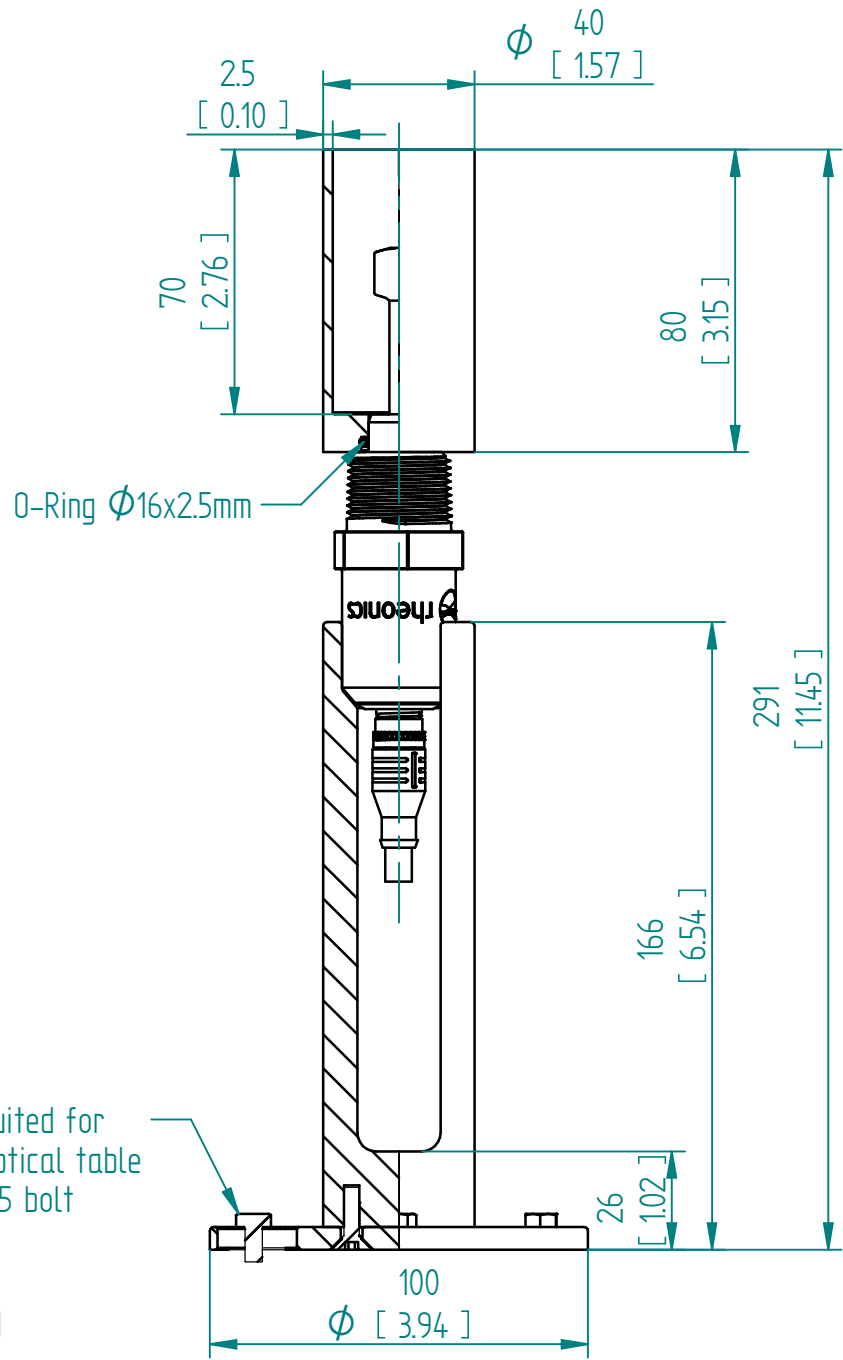

Units: mm
[inch]

Sensor Probe Laboratory Setup

This drawing remains property of rheonics. It may be neither copied nor informed to third persons or competitors without our approval. (2 paragraph 1 fig.7 copyright act of 9th Sept. 1965)



Protected by US and International patents granted and pending