

Pressure-Rating of the sensor probe	As specified in order confirmation
Material	316L
Process connection	Tri-Clamp 1.5"
Compatible with	ISO1127 DN 20* / 25 / 32
	DIN 32676 DN 25 / 32 / 40
	ASME-BPE 1.5"
Order Code	SRV-HS-X3-15T

*seal gasket will be over the weld line, care should be taken to use sufficiently conformal gaskets to seal

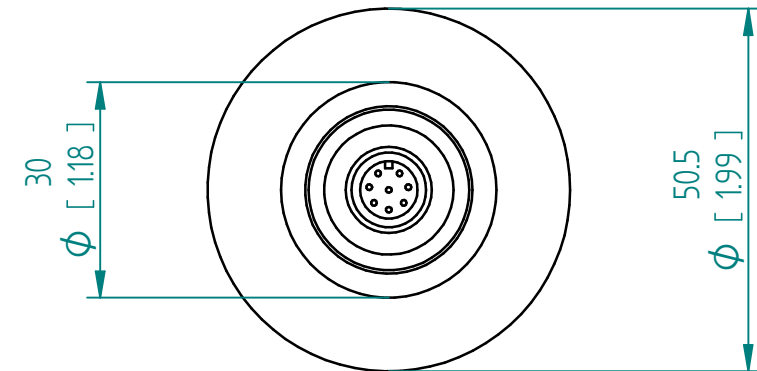

Units: mm
[inch]

SRV-HS-X3-15T Tri Clamp 1.5"

This drawing remains property of rheonics. It may be neither copied nor informed to third persons or competitors without our approval. (2 § paragraph 1 fig.7 copyright act of 9th Sept. 1965)

Protected by US and International patents granted and pending