

Material	Stainless Steel 1.4301
Description	Stand for SR- Type sensor

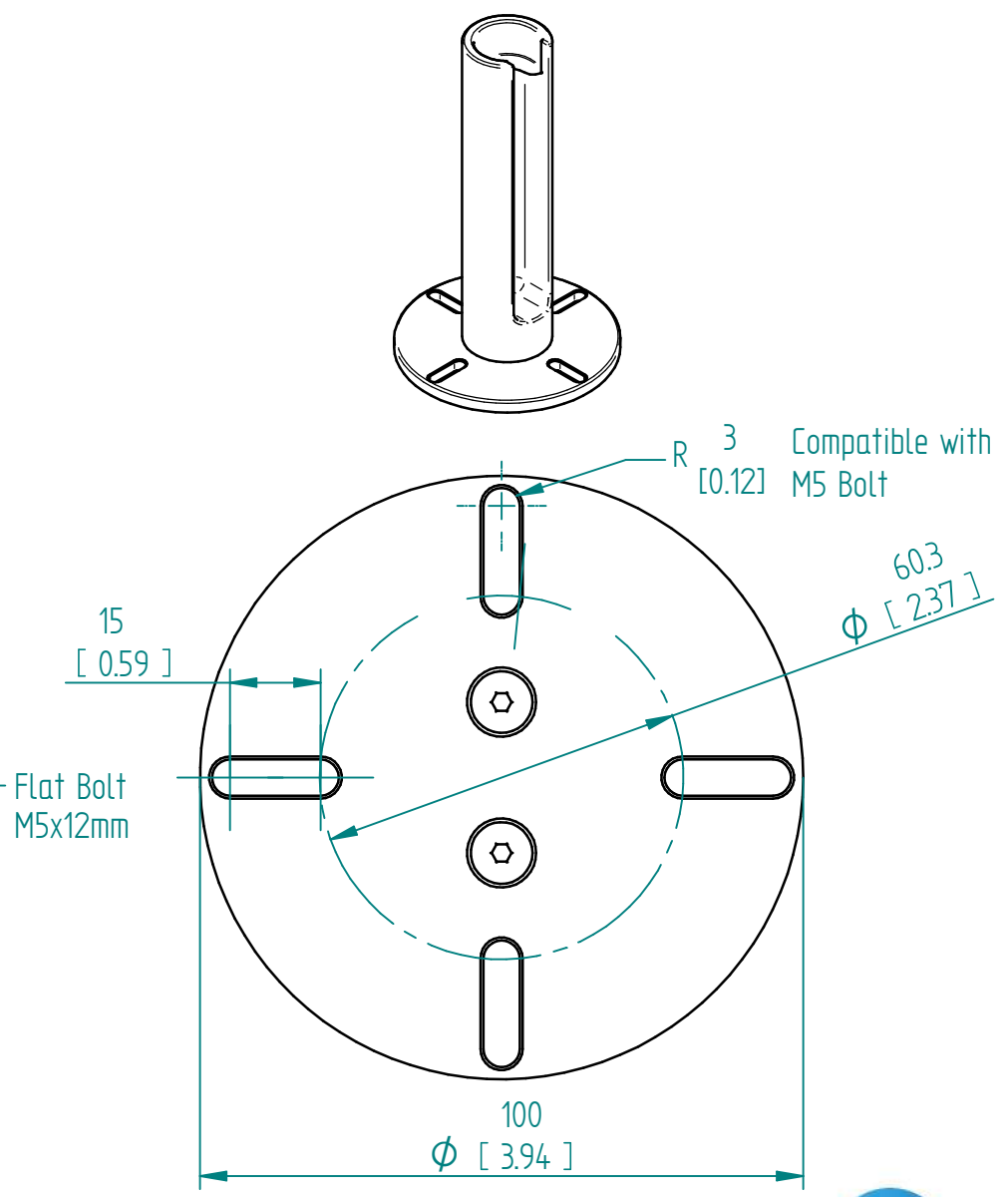
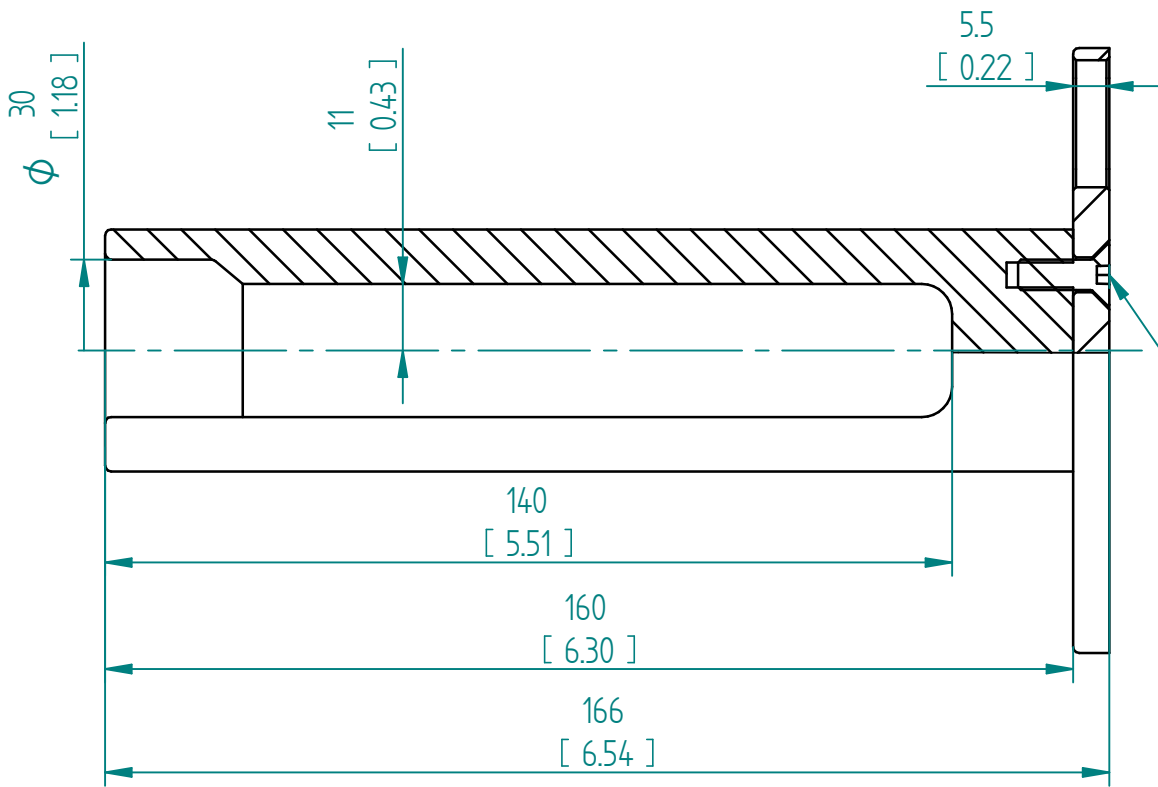

Units: mm [inch]

# SCS-00A-ME Sensor Probe Stand

This drawing remains property of rheonics. It may be neither copied nor informed to third persons or competitors without our approval. ( 2 paragraph 1 fig.7 copyright act of 9th Sept. 1965)



Protected by US and International patents granted and pending

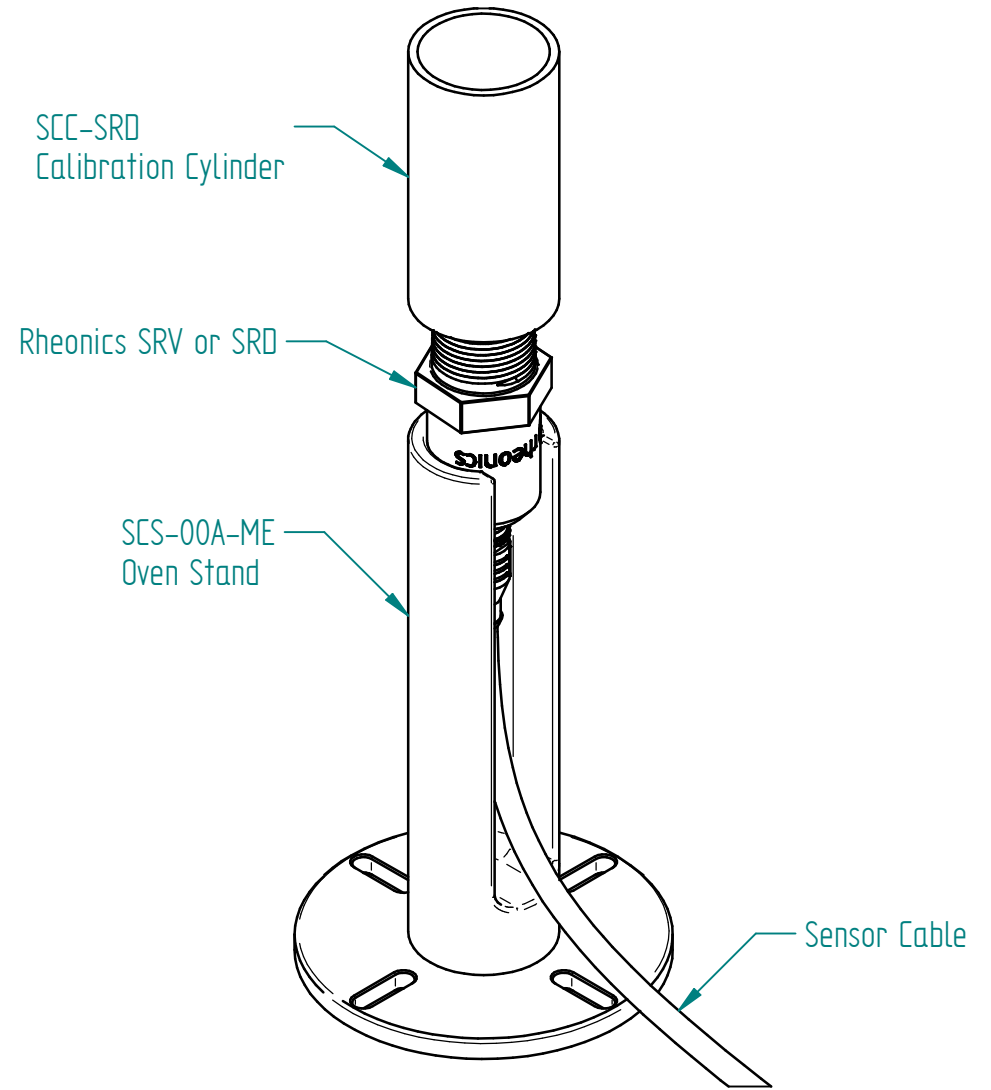
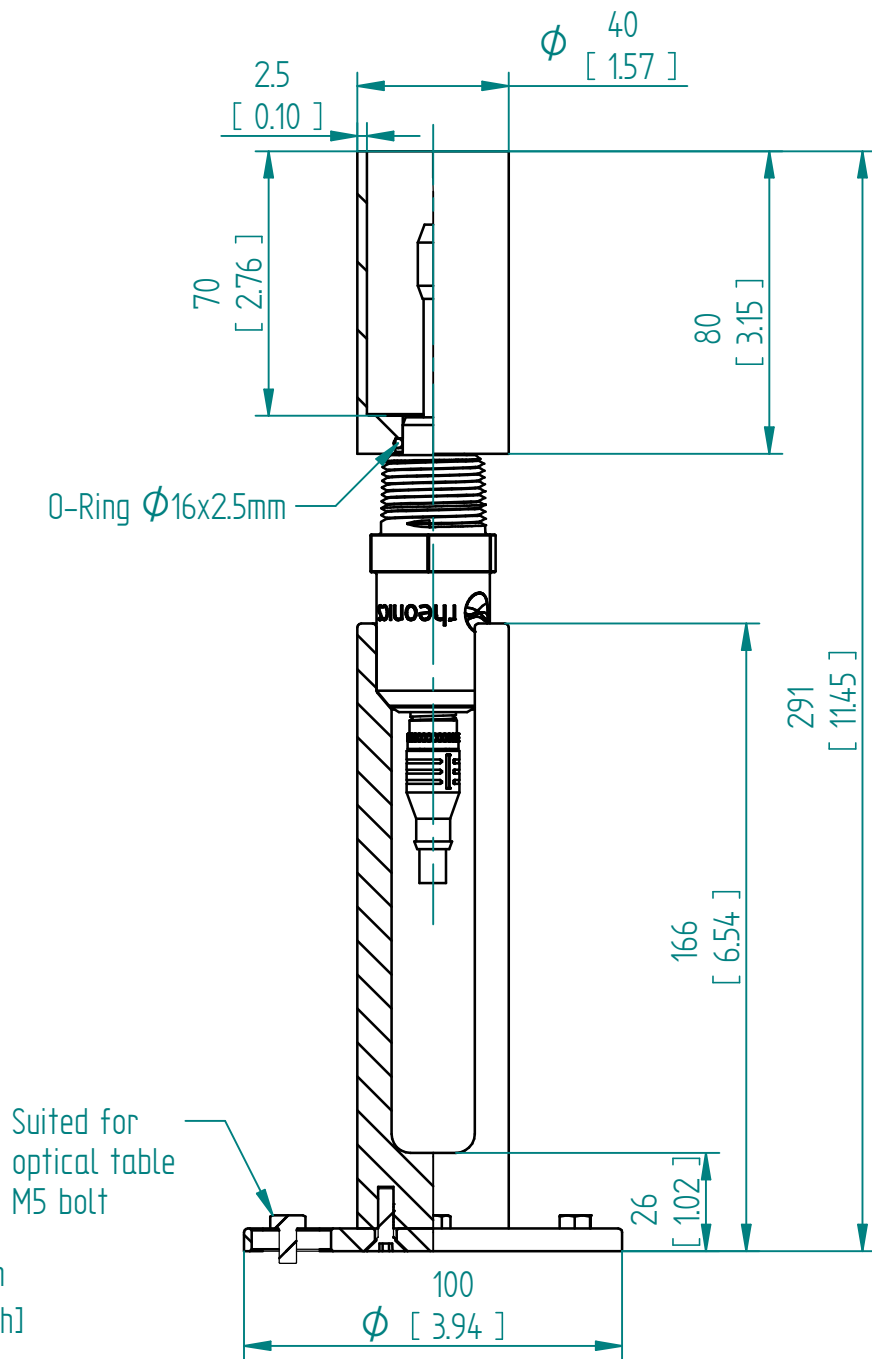

Units: mm  
[inch]

## Sensor Probe Laboratory Setup

This drawing remains property of rheonics. It may be neither copied nor informed to third persons or competitors without our approval. ( 2 paragraph 1 fig.7 copyright act of 9th Sept. 1965)