

Pressure rating weldolet	500 bar (7500 psi)
Material	316L
Thread	G 1/2"

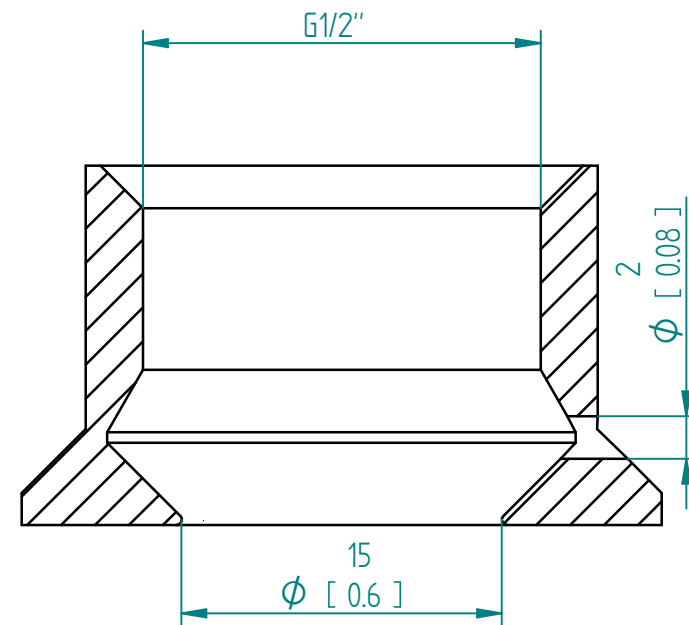
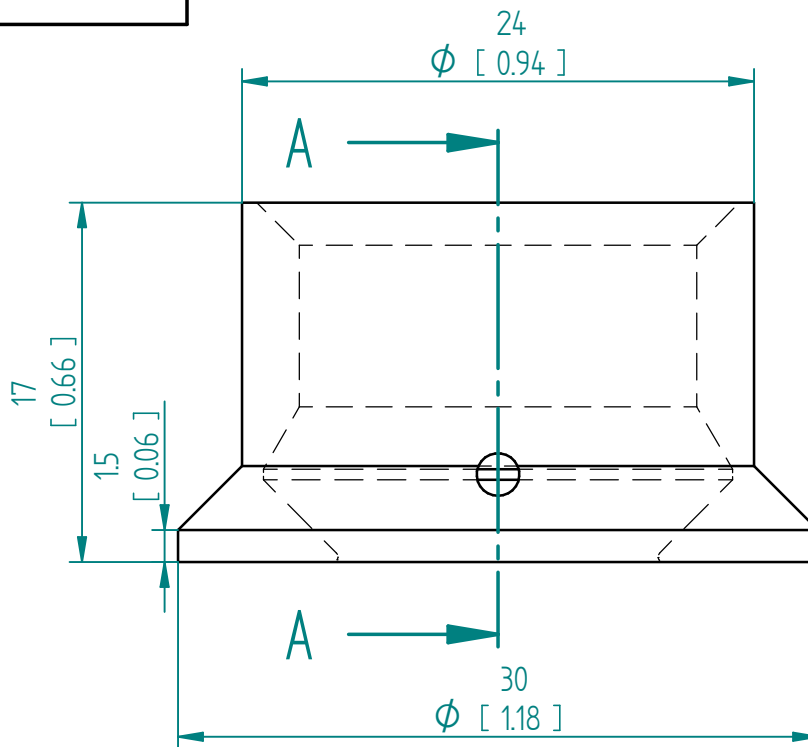
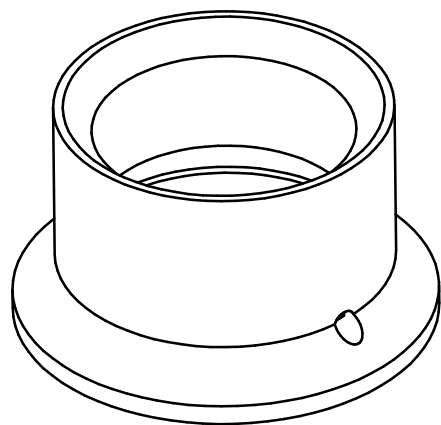

Section A-A

Units: mm
[inch]

HAW-12G-MTN G1/2" Thin Metal Seal Weldolet

This drawing remains property of rheonics. It may be neither copied nor informed to third persons or competitors without our approval. (2 paragraph 1 fig.7 copyright act of 9th Sept. 1965)

Protected by US and International patents granted and pending

rheonics • Switzerland • USA • www.rheonics.com • info@rheonics.com +41 52 511 32 00 +1 713 364 5427

Release: 2305

rheonics



inline process
density and viscosity
monitoring

SRV-12G

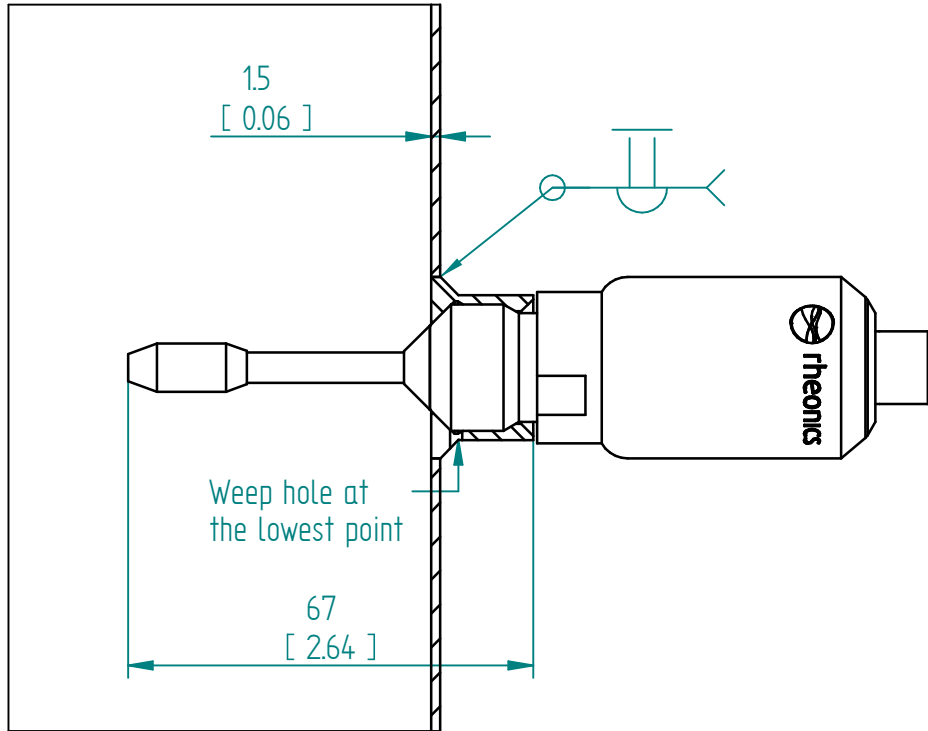

SRD-12G

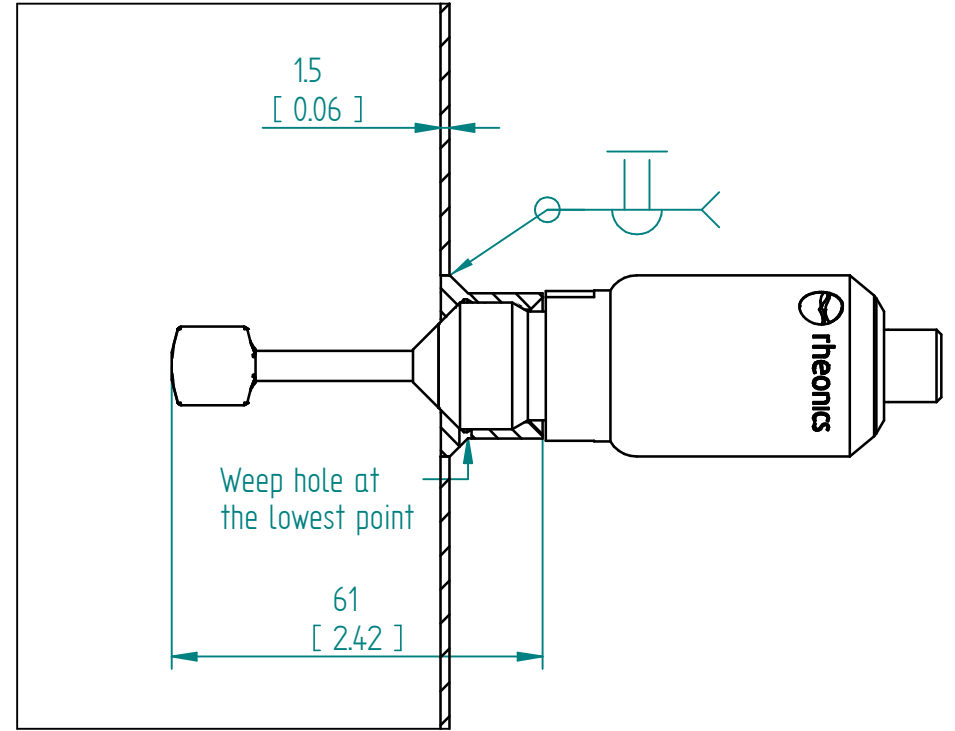

Units: mm
[inch]

HAW-12G-MTN Installation drawing

This drawing remains property of rheonics. It may be neither copied nor informed to third persons or competitors without our approval. (2 paragraph 1 fig.7 copyright act of 9th Sept. 1965)



rheonics

inline process
density and viscosity
monitoring

Protected by US and International patents granted and pending

rheonics • Switzerland • USA • www.rheonics.com • info@rheonics.com +41 52 511 32 00 +1 713 364 5427

Release: 2305