

Pressure rating	200 bar (2900 psi)
Material	316L
Fluid volume	60 ml

Only to be used with correct pressure rating on the SRV sensor and process connection.

SRV with 1.5" TriClamp (DN40) Process Connection

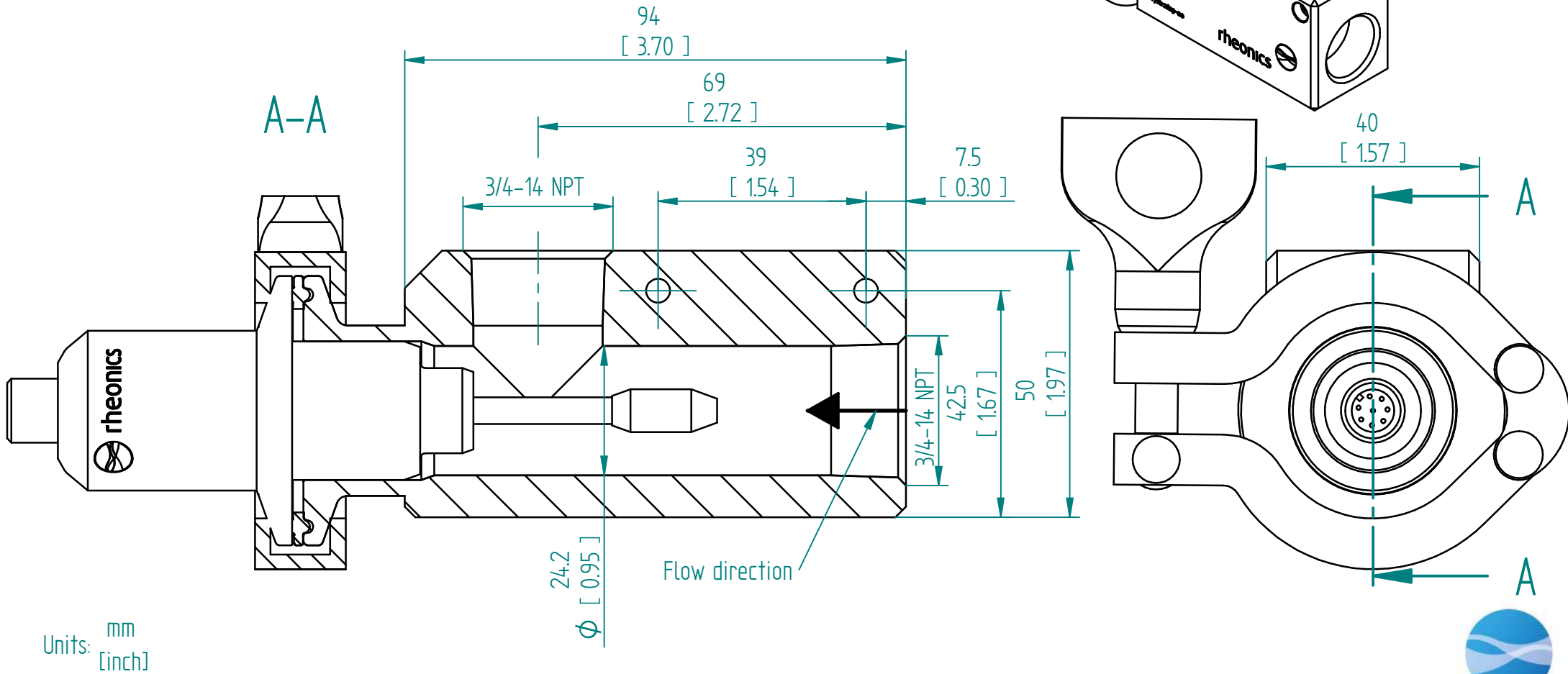
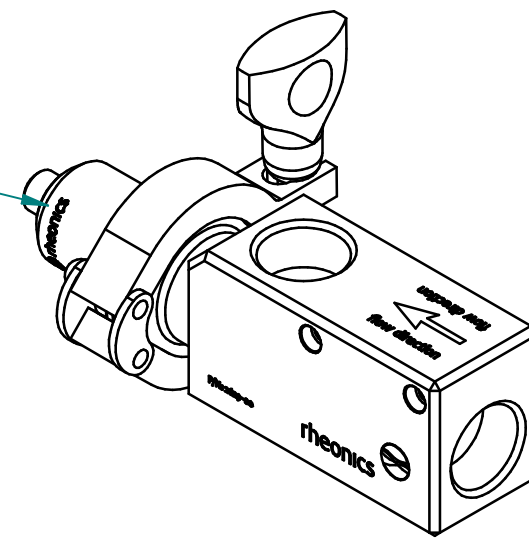

SRV 1.5" Tri-Clamp IFC-15T-34N-SRV

This drawing remains property of rheonics. It may be neither copied nor informed to third persons or competitors without our approval. (2 paragraph 1 fig.7 copyright act of 9th Sept. 1965)

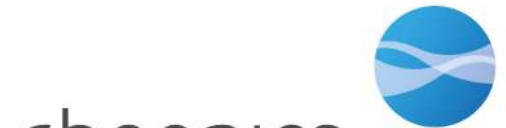

inline process
density and viscosity
monitoring

Protected by US and International patents granted and pending

rheonics • Switzerland • USA • www.rheonics.com • info@rheonics.com +41 52 511 32 00 +1 713 364 5427

Release: 2503

For mounting use
- 8-32 x 1 3/4 in. screws or with
- M4 x 45 mm screws

For better cleanability,
mount adapter at an angle
as shown in the image to the right

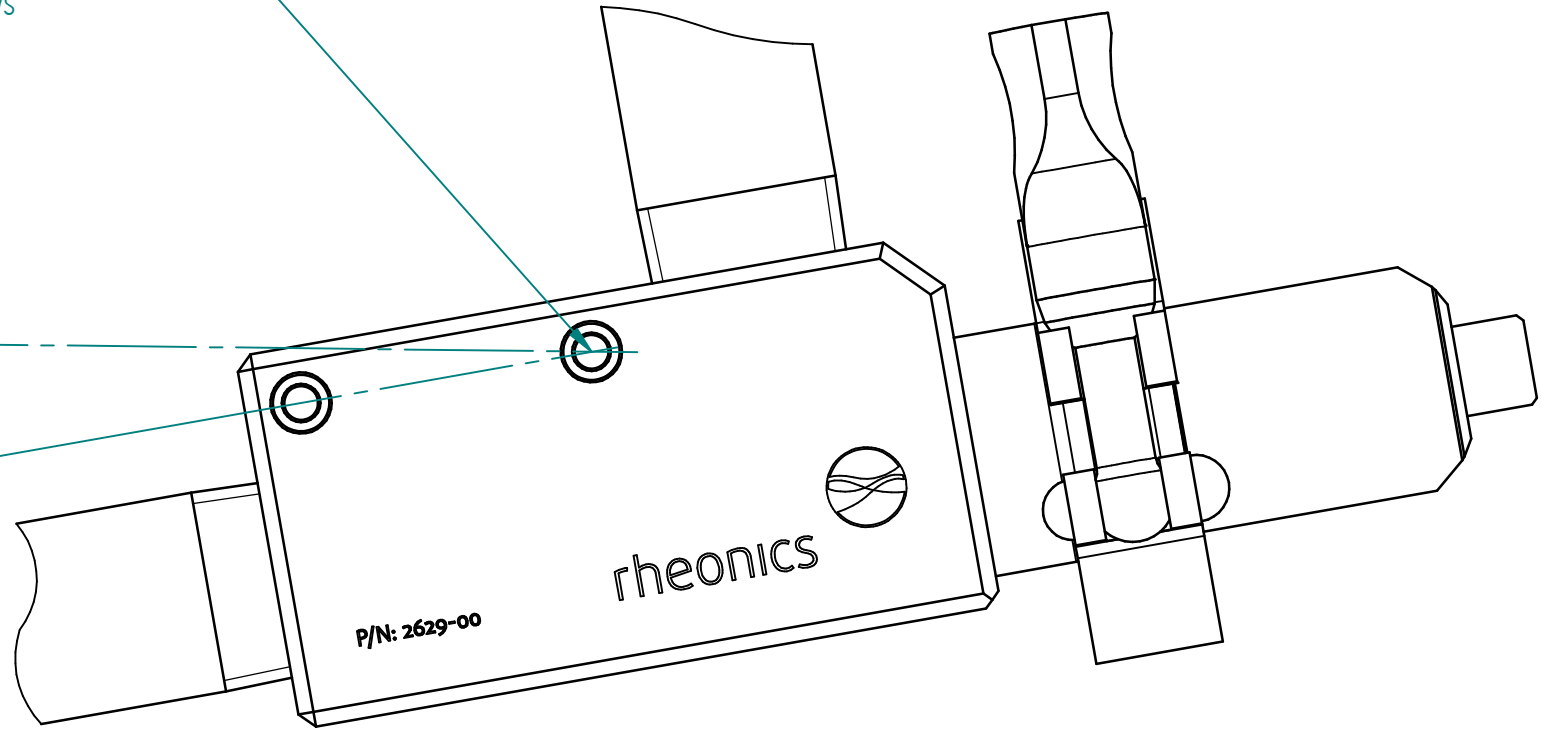

Units: mm
[inch]

SRV 1.5" Tri-Clamp IFC-15T-34N-SRV

This drawing remains property of rheonics. It may be neither copied nor informed to third persons or competitors without our approval. (2 paragraph 1 fig.7 copyright act of 9th Sept. 1965)

rheonics 
inline process
density and viscosity
monitoring

Protected by US and International patents granted and pending

rheonics • Switzerland • USA • www.rheonics.com • info@rheonics.com +41 52 511 32 00 +1 713 364 5427

Release: 2503