

ID	Description	Qty.
1	SME-TR Lid	1
2	Lid O-ring	1
3	Electronics Standoff	4
4	Electronics Module	1
5	In-housing Grounding Terminal	1
6	Lid Lock Screw	1
7	Cable Gland	3
8	SME-TR/TRD Housing	1
9	External Grounding Terminal	1
10	Rating and Specification Plate	1

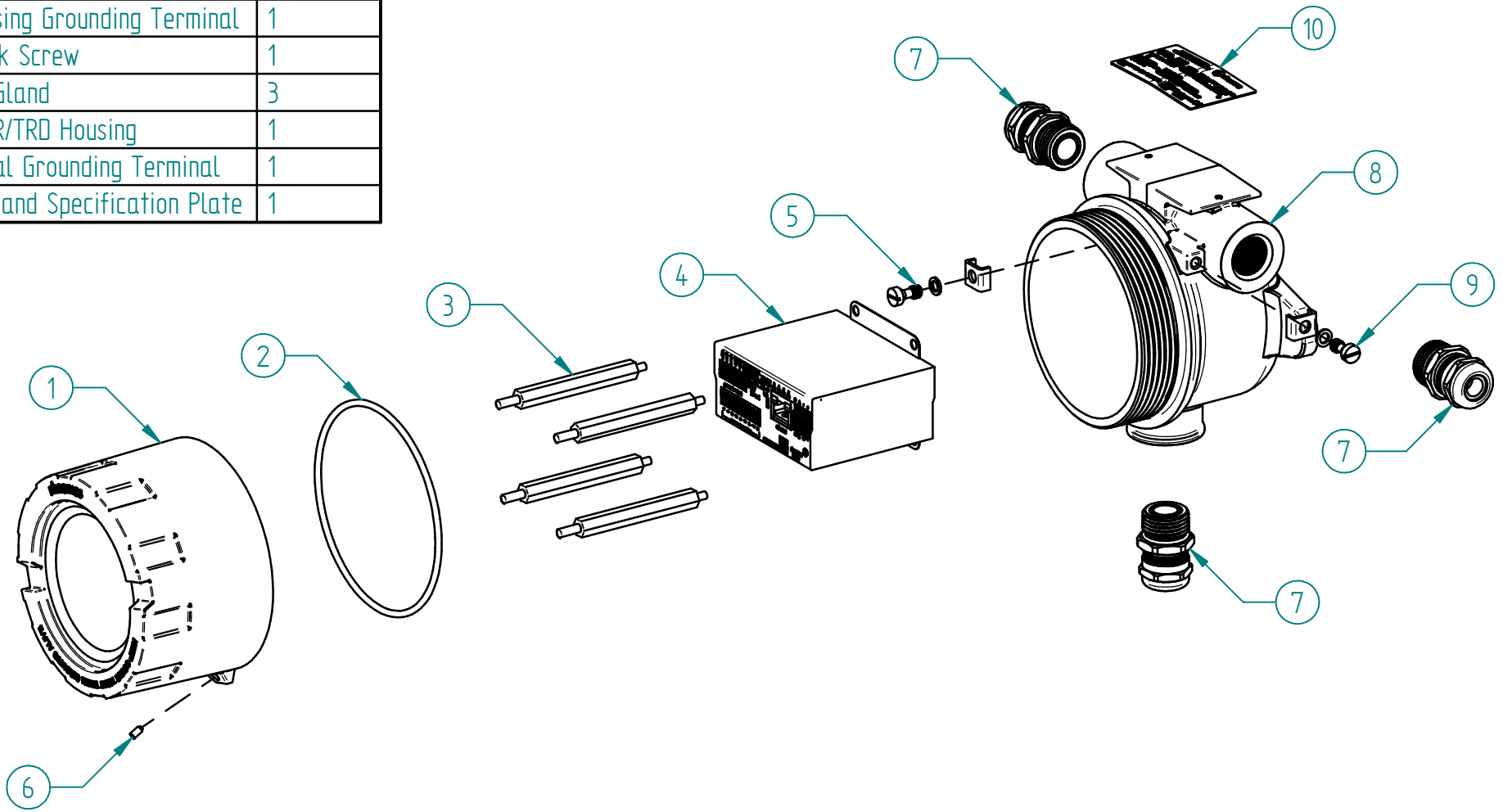

# SME-TR Parts List

No warranty is made for the correctness of the third party drawings. Dimensions are adapted from publically available drawings. Customer should check and confirm that the retrofit sensor has the dimensions and flange specifications for a correct installation in their existing location.  
 This drawing remains property of rheonics. It may be neither copied nor informed to third persons or competitors without our approval. ( 2 paragraph 1 fig.7 copyright act of 9th Sept. 1965)



Protected by US and International patents granted and pending